



Submersible Pump

Model S6E1-E60

Size 6"



PUMP SPECIFICATIONS

Diffuser: G-R Hard Iron;
Maximum Operating Pressure 111 psi (765 kPa).*

Impeller: G-R Hard Iron.

Suction Head: Gray Iron 30.

Seal Plate: G-R Hard Iron.

Motor Housing: Aluminum Alloy 356-T6.

Wear Ring: Copper Alloy 83600.

Motor Shaft: Stainless Steel 17-4PH.

Bearings: Upper - Two Synthetic Seals, Single Row Ball Bearing.
Lower - Two Shields, Double Row Ball Bearing.

Discharge Flange: Gray Iron 30.

Gaskets: Cork with Nitrile Binder (NC710).

O-Rings: Buna-N.

Wetted Hardware: Standard Plated Steel and Stainless Steel.

Strainer: Urethane Coated Steel; 48% Open Area,
0.50" (12.7 mm) Diameter Openings.

Base Plate: Aluminum Alloy 356-T6.

Hoisting Bail: Urethane Coated Steel.

Standard Equipment

NEMA Type 3R Rainproof Control Box. (See Section 130, Page 95.)

Provides On-Off, Circuit Breaker and Motor Overload Protection.

Staging Adapter.

Optional Equipment

Liquid Level Control: (See Sec. 130, Page 150.)

- Turtle Type Pressure Activated Level Switch.
- Float Activated Level Switch.

MOTOR/CABLE SPECIFICATIONS

Motor: Air Filled Enclosure with Thermal Overload Protection; 60 H.P.; 3450 R.P.M.; Three Phase: 460/575 Volt, 60 Hz, 66.0/52.8 Full Load AMPS, 48.0 kW (Max.)

Power Cable: 9 Wire; Type SPC; (3) 6 AWG. Power Conductors, (1) 6 AWG. Ground Conductor, (4) 14 AWG. Control Conductors and (1) 8 AWG. Ground Check. Nominal Length 50 Feet (15 m). Standard. (Specify Alternate Length at Time of Order.)

Recommended Generator Size: 150 kW Across-the-Line Start.
75 kW for Reduced Voltage Starting.

* Consult Factory for Applications Exceeding
Maximum Pressure and/or Temperature Indicated.

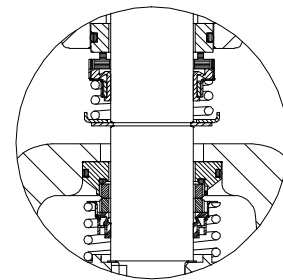
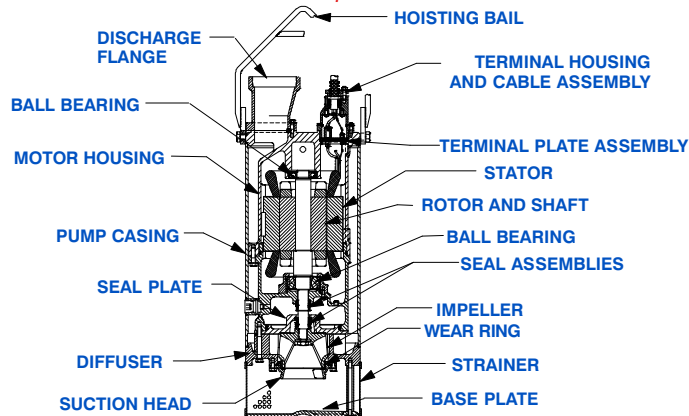

SEAL SPECIFICATIONS

Tandem, Oil Lubricated.

Upper Seal: Type 21, Mechanical. Carbon Rotating Face. Ni-Resist Stationary Face. Fluorocarbon Elastomers (DuPont Viton® or Equivalent). Stainless Steel 18-8 Cage and Spring.

Lower Seal: Type 2, Mechanical. Silicon Carbide Rotating Face and Tungsten Titanium Carbide Stationary Face. Stainless Steel 316, Stationary Seat. Fluorocarbon Elastomers (DuPont Viton® or Equivalent). Stainless Steel 18-8 Cage and Spring.

Maximum Temperature of Liquid Pumped, 122°F (50°C).*



GORMAN-RUPP PUMPS

www.grpumps.com

Specifications Subject to Change Without Notice

Printed in U.S.A.

Specification Data

SECTION 130, PAGE 1400C

APPROXIMATE
DIMENSIONS and WEIGHTS

NET WEIGHT: 901 LBS. (408,7 KG.)
SHIPPING WEIGHT: 1020 LBS. (462,7 KG.)
EXPORT CRATE: 12.2 CU. FT. (0,35 CU. M.)

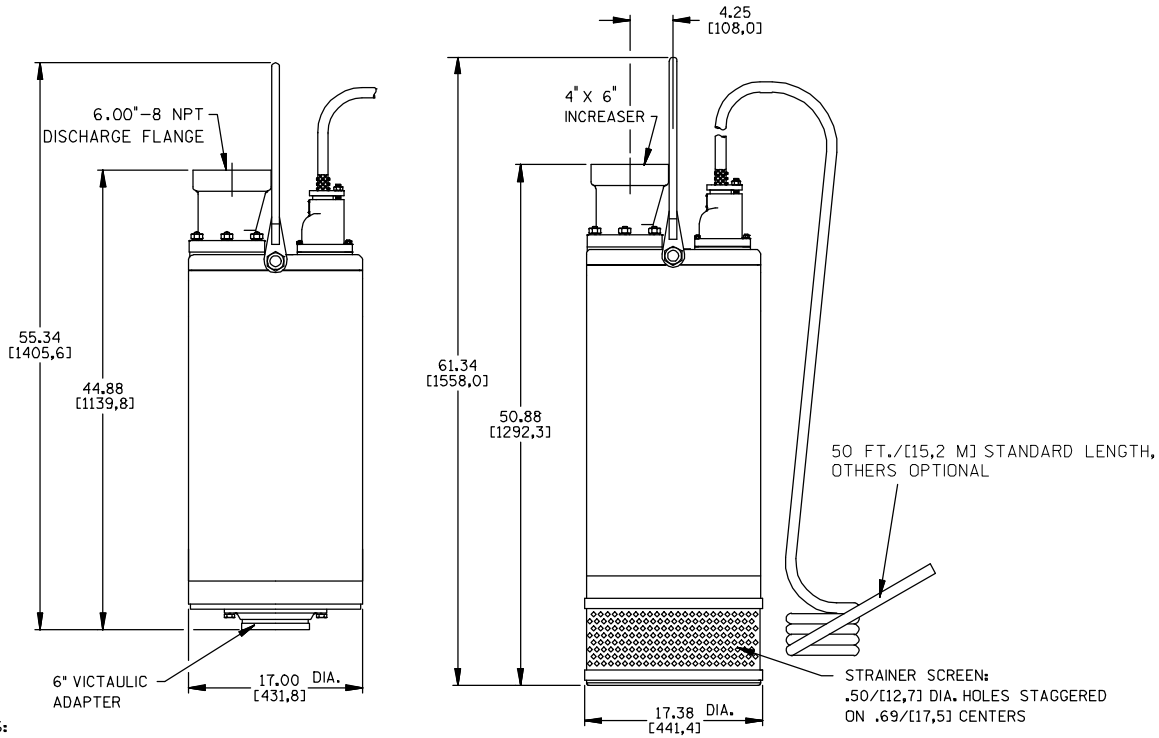

DIMENSIONS:
INCHES
[MILLIMETERS]

Victaulic is a Registered Trademark of Victaulic Company of America

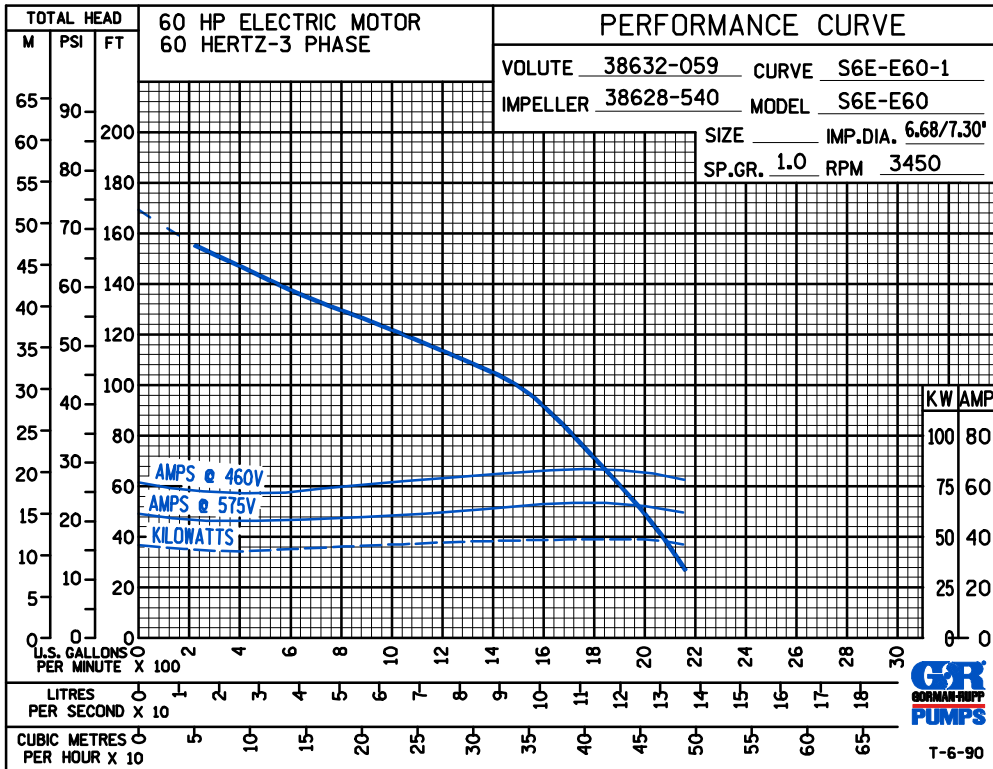

GORMAN-RUPP PUMPS

www.grpumps.com

Specifications Subject to Change Without Notice

Printed in U.S.A.